

## Providing the next generation of safety systems for the automotive industry

Advanced technologies are providing the next generation of safety systems for the automotive industry.

The IMAPCAR® image processor for automobiles can detect nearby objects such as vehicles, pedestrians and lane markers in real time, enabling automobile manufacturers to easily implement safety mechanisms and collision prevention systems.

IMAPCAR is five times faster than the leading automotive image processor, boasting performance of up to 100 giga (billion) operations per second (GOPS). Using parallel processing technology throughout its 128 processing elements, the IMAPCAR processor provides the advanced performance necessary for real-time identification of objects.

Both the autonomous driving and the collision detection demonstrations show how the IMAPCAR processor may help prevent accidents and enhance driver safety.

### Functionality

IMAPCAR can be applied in various automotive safety systems, including adaptive cruise control (ACC), rear-end collision warning, lane departure and obstacle detection. A small camera is installed on the front and/or rear of the vehicle. Intelligent image-processing software analyzes the images in real time, calculating the vehicle's position. The processor can recognize if there are obstacles or pedestrians, if the vehicle is leaving its lane or if it is accelerating or decelerating.

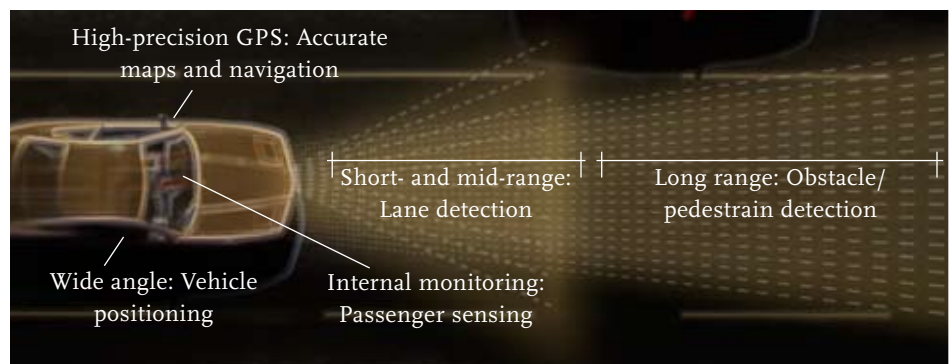

*In the collision detection demonstration, the display flashes a warning when the car gets within an unsafe distance of the other vehicle.*

*In the autonomous driving demonstration, IMAPCAR "sees" the lane markers and guides the car along the course.*

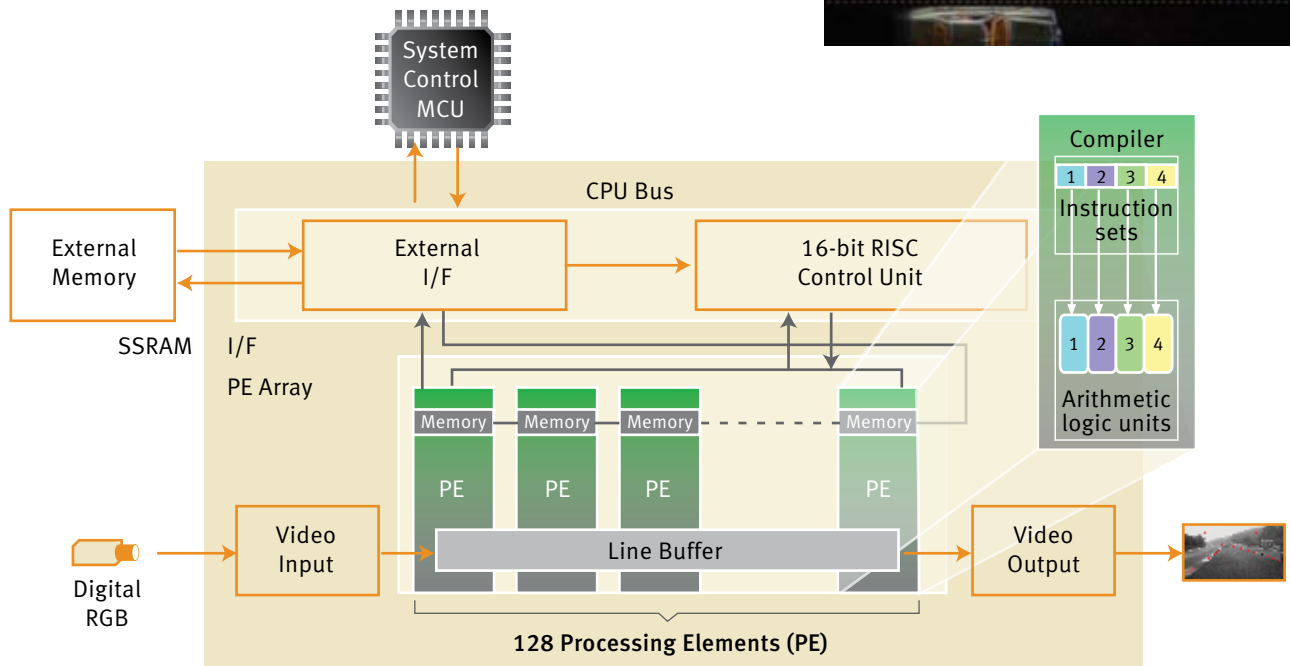
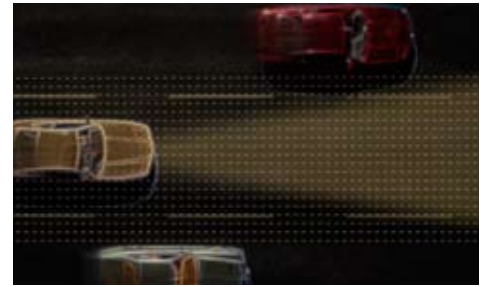

## Architecture

Parallel processing enables simultaneous processing of large data volumes as follows.

1. 128 processing elements (PE) follow a single command using the single-instruction, multiple-data (SIMD) method.
2. Each PE has a separate random access memory (RAM). The PEs simultaneously issue four commands in one cycle using the very large instruction word (VLIW) method.

© October 2006 NEC Electronics America, Inc. All rights reserved.  
Printed in U.S.A. on recycled paper using soy ink.

Document No. U18358EU1V0PF00

**NEC Electronics America, Inc.**  
Corporate Headquarters  
2880 Scott Boulevard  
Santa Clara, CA 95050-2554  
1-408-588-6000  
www.am.necel.com

**NEC Electronics America, Inc.**  
Automotive Business Unit  
6555 N. State Highway 161  
9th Floor  
Irving, TX 75039  
1-214-262-7950

**NEC Electronics Corporation**  
1753 Shimonumabe, Nakahara-Ku  
Kawasaki, Kanagawa 211-8668  
Japan  
81-44-435-5111  
www.necel.com

**NEC Electronics (Europe) GmbH**  
Aracadienstr. 10  
40472 Dusseldorf, Germany  
49-211-6503-0  
www.eu.necel.com