



78K0R/Kx3 Microcontroller Sample Program Operation Manual (Interval Timer/Square Wave Output (Timer Array Unit), C Source)

This software is for reference only and NEC Electronics does not guarantee its operation.
Thoroughly evaluate this software on your set prior to use.

ZUD-CC-07-0072-E
January, 2008

1st Product Solution Group, Multipurpose Microcomputer Systems Division,
Microcomputer Operations Unit
NEC Electronics Corporation

• **The information in this document is current as of January, 2008. The information is subject to change without notice. For actual design-in, refer to the latest publications of NEC Electronics data sheets or data books, etc., for the most up-to-date specifications of NEC Electronics products. Not all products and/or types are available in every country. Please check with an NEC Electronics sales representative for availability and additional information.**

- No part of this document may be copied or reproduced in any form or by any means without the prior written consent of NEC Electronics. NEC Electronics assumes no responsibility for any errors that may appear in this document.
- NEC Electronics does not assume any liability for infringement of patents, copyrights or other intellectual property rights of third parties by or arising from the use of NEC Electronics products listed in this document or any other liability arising from the use of such products. No license, express, implied or otherwise, is granted under any patents, copyrights or other intellectual property rights of NEC Electronics or others.
- Descriptions of circuits, software and other related information in this document are provided for illustrative purposes in semiconductor product operation and application examples. The incorporation of these circuits, software and information in the design of a customer's equipment shall be done under the full responsibility of the customer. NEC Electronics assumes no responsibility for any losses incurred by customers or third parties arising from the use of these circuits, software and information.
- While NEC Electronics endeavors to enhance the quality, reliability and safety of NEC Electronics products, customers agree and acknowledge that the possibility of defects thereof cannot be eliminated entirely. To minimize risks of damage to property or injury (including death) to persons arising from defects in NEC Electronics products, customers must incorporate sufficient safety measures in their design, such as redundancy, fire-containment and anti-failure features.
- NEC Electronics products are classified into the following three quality grades: "Standard", "Special" and "Specific".

The "Specific" quality grade applies only to NEC Electronics products developed based on a customer-designated "quality assurance program" for a specific application. The recommended applications of an NEC Electronics product depend on its quality grade, as indicated below. Customers must check the quality grade of each NEC Electronics product before using it in a particular application.

"Standard": Computers, office equipment, communications equipment, test and measurement equipment, audio and visual equipment, home electronic appliances, machine tools, personal electronic equipment and industrial robots.

"Special": Transportation equipment (automobiles, trains, ships, etc.), traffic control systems, anti-disaster systems, anti-crime systems, safety equipment and medical equipment (not specifically designed for life support).

"Specific": Aircraft, aerospace equipment, submersible repeaters, nuclear reactor control systems, life support systems and medical equipment for life support, etc.

The quality grade of NEC Electronics products is "Standard" unless otherwise expressly specified in NEC Electronics data sheets or data books, etc. If customers wish to use NEC Electronics products in applications not intended by NEC Electronics, they must contact an NEC Electronics sales representative in advance to determine NEC Electronics' willingness to support a given application.

(Note)

- (1) "NEC Electronics" as used in this statement means NEC Electronics Corporation and also includes its majority-owned subsidiaries.
- (2) "NEC Electronics products" means any product developed or manufactured by or for NEC Electronics (as defined above).

CONTENTS

1. OVERVIEW.....4

2. RESOURCES USED5

3. SOFTWARE CONFIGURATION.....6

4. FUNCTION EXPLANATIONS7

5. FLOWCHARTS.....9

1. OVERVIEW

This manual explains sample program functions of the interval timer/square wave output for the 78K0R/Kx3.

In this sample program, an interrupt is generated at intervals of 10 ms (every 2,500 counts) by using a count clock whose frequency is $1/2^5$ of that of the main clock (8 MHz).

A toggle operation is performed by using output pin P17 to output a square wave with a cycle of 20 ms and a duty factor of 50% when the interrupt is generated.

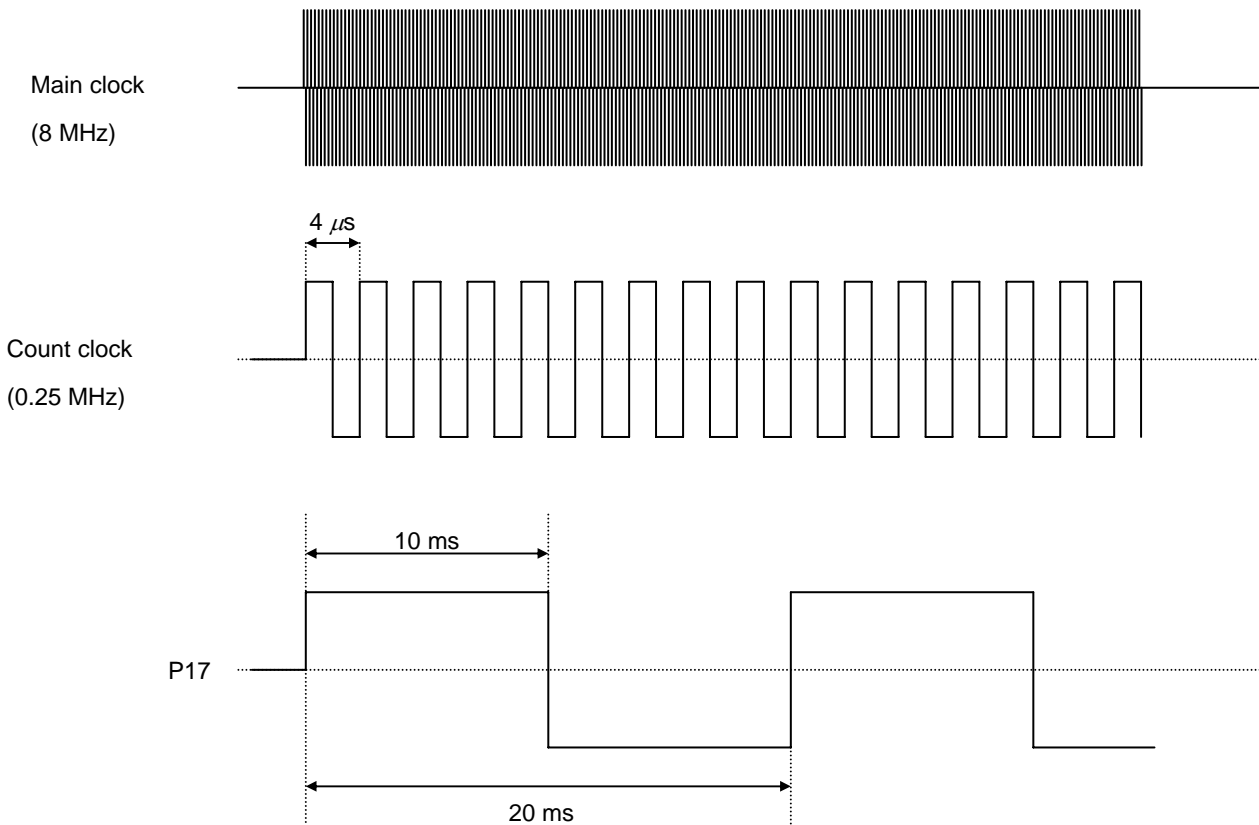

2. RESOURCES USED

Resource	Description	Remark
Main clock specification	Internal high-speed oscillator used (8 MHz (TYP.))	Supplied to CPU and peripheral hardware
	High-speed system clock used (20 MHz)	Oscillated by initial processing
Subclock	XT1 (32.768 kHz)	Oscillated by initial processing
Related hardware	Peripheral enable register 0 (PER0)	Controls the input clock of the timer array unit.
	Timer clock select register 0 (TPS0)	Operation clock: CK01 (1/2 ⁵), 0.25 MHz (4 μ s)
	Timer mode register 02 (TMR02)	Operation clock: CK01, 8 MHz (0.125 μ s)
	Timer data register 02 (TDR02)	Interval cycle: 10 ms (4 μ s \times 2500)
	Timer output mode register 0 (TOM0)	Channel 2 toggle operation mode
	Timer output level register 0 (TOL0)	Channel 2 positive logic output (active high)
	Timer output register 0 (TO0)	Channel 2 timer output value is "0".
	Timer output enable register 0 (TOE0)	Channel 2 timer output enable (valid when square wave is output)
	Timer channel start register 0 (TS0)	
	Timer channel stop register 0 (TTO)	
	Port mode register (PM1)	
	Port register (P1)	
I/O	Output: TO02 (P17)	
Interrupt	Timer channel 2	
Others	Not used	

3. SOFTWARE CONFIGURATION

Files

File Name	Processing Outline
K0R_def.h	Definition file
K0R_init.c	Initialization processing
K0R_ext.h	External declaration
K0R_main.c	Main processing
K0R_sfr_set.c	Interval timer/square wave output

4. FUNCTION EXPLANATIONS

[File name]

K0R_main.c

Function

Function Name	Processing Outline	Argument	Return Value
main	Interval timer/square wave output main processing	None	None

Function explanations

Function name	main
Processing	Interval timer/square wave output main processing
Argument	–
Return value	–
Description	Executes initialization processing and then starts interval timer/square wave output. After timer channel 2 interrupt request flag is set to ON, clears it.
Remark	–

[File name]

K0R_sfr_set.c

Functions

Function Name	Processing Outline	Argument	Return Value
STM_IINI	Initializes interval timer/square wave output.	None	None
STM_ISTT	Starts interval timer/square wave output operation.	None	None
STM_ISTP	Stops interval timer/square wave output operation.	None	None

Function explanations

Function name	STM_IINI
Processing	Initializes interval timer/square wave output.
Argument	–
Return value	–
Description	<p>Initializes the timer array unit.</p> <ul style="list-style-type: none"> • Supplies a timer array unit input clock. • Sets the clock frequency of CK01 to 4 μs. <p>Initializes timer channel 2.</p> <ul style="list-style-type: none"> • Uses operation clock CK01 and sets the interval timer mode. • Sets the generation cycle to 10 ms. • Enables output.
Remark	–

Function name	STM_ISTT
Processing	Starts interval timer/square wave output operation.
Argument	–
Return value	–
Description	<p>Starts timer channel 2 operation.</p> <ul style="list-style-type: none"> • Enables output. • Starts operation. • Clears interrupt request flag. • Enables interrupts.
Remark	–

Function name	STM_ISTP
Processing	Stops interval timer/square wave output operation.
Argument	–
Return value	–
Description	<p>Stops timer channel 2 operation.</p> <ul style="list-style-type: none"> • Stops operation. • Disables output.
Remark	–

5. FLOWCHARTS

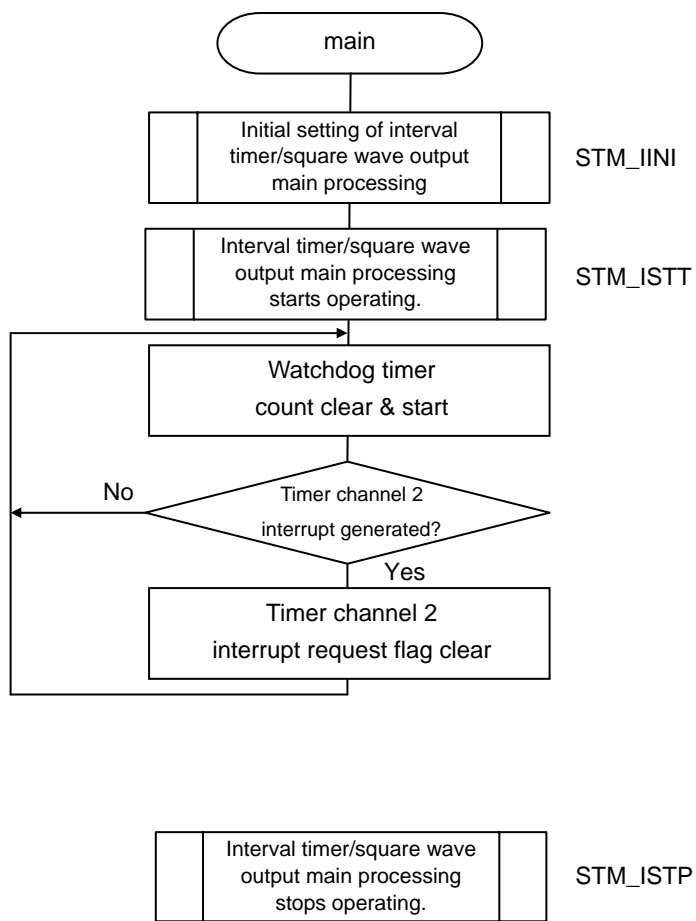

Remark n = 0 to 7 can be set.
 n = 2 for this sample program.

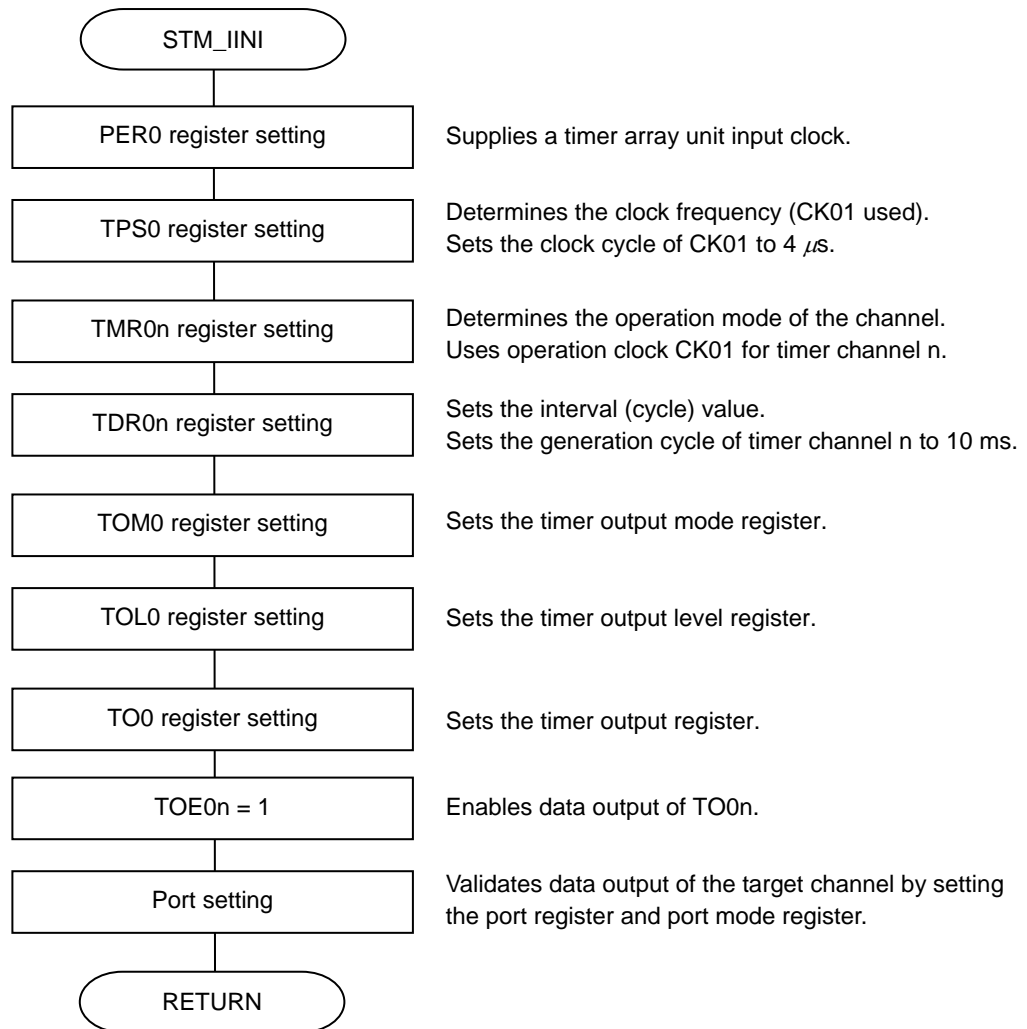

Remark n = 0 to 7 can be set.

n = 2 for this sample program.

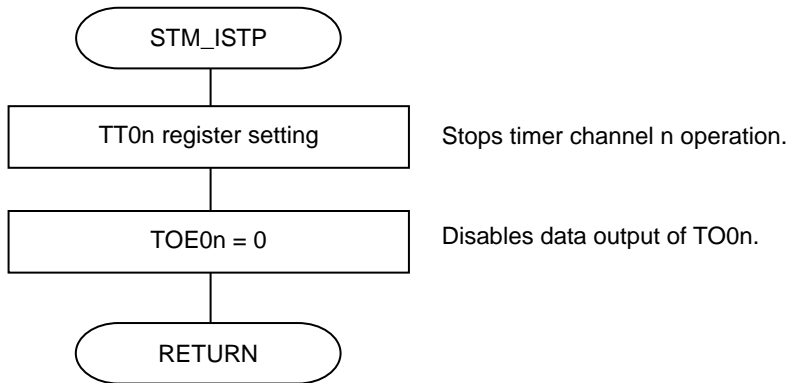
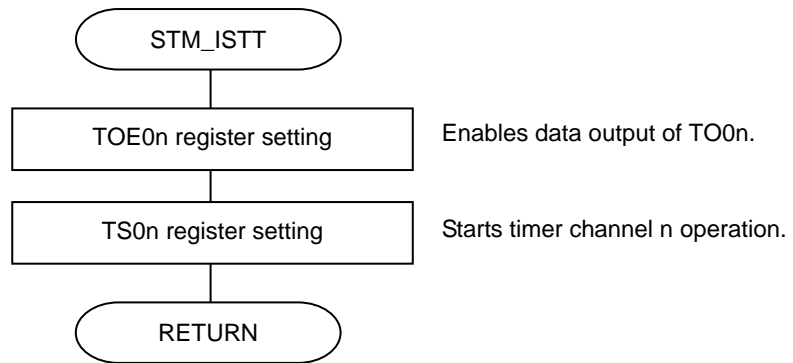

Remark n = 0 to 7 can be set.
n = 2 for this sample program.