

Description

The VR4131 is the MIPS per mW leader of NEC Electronics America's VR Series™ product line. This high-performance 64-bit RISC microprocessor employing the MIPS I, II, III, and MIPS16 instruction sets delivers 1545 MIPS per watt, one of the highest-performance, lowest power ratios currently available. In addition to an ultra-low-power-consuming VR4130 CPU core, the device has cache memory, two-way superscalar pipeline, memory management unit, and peripherals including a DMA interface, serial interface, IrDA® interface, and real-time clock, among others. The VR4131 also has a 32-bit external memory bus and supports a PCI bus interface for external devices, allowing easy embedded systems development.

Specifications

- High performance/low power ratio of 1545 MIPS per watt
- Maximum power consumption
 - 220 mW at 200 MHz (typical)
- High-performance operation
 - 340 Dhrystone MIPS at 200 MHz
- Storage systems
- Wireless LAN access points
- Network interface cards (NICs)
- Server farms
- Information appliances
 - Portable Internet appliances
 - Pocket PCs
- Control applications
- Supply voltage: 1.5 V (internal) and 3.3 V (external)
- 224-pin FPBGA (16 mm x 16 mm)
- Pin-compatible with NEC's VR4122 (except N-wire)
- Full industrial -40°C to +85°C ambient operating temperature range

Applications

Block Diagram

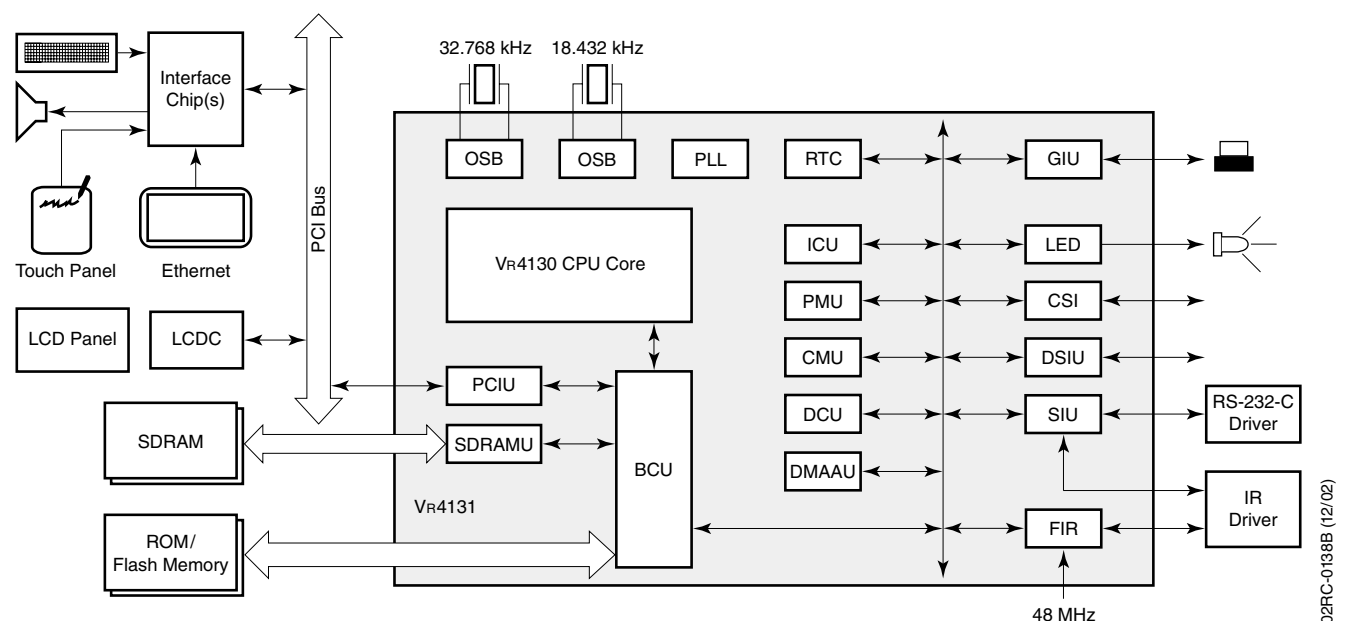

Features

CPU

- 64-bit MIPS RISC CPU core (VR4130 equivalent)
- Two-way superscalar pipeline
- Internal 64-bit data processing
- Big and little endian modes

Powerful MIPS Instructions

- MIPS I, II, III instruction sets (without FPU instructions)
- MIPS16 instruction set
- High-speed product/sum instructions
- Multiply-add instruction for product-sum operation of $32 \times 32 + 64$ bits with one clock

Clocks

- External clock input: 32.768 kHz
- Internal CPU core and peripheral unit operation: 18.432 MHz
- IrDA interface: 48 MHz
- Programmable clock management for each on-chip peripheral

Power Management Modes

- Full speed: normal operation with all clocks functional
- Standby: internal clocks stop except for timer or interrupt-related clocks
- Suspend: bus clock and internal clocks stop except for timer or interrupt-related clocks
- eXsuspend: same as Suspend mode, except that can turn off the internal PLL
- Hibernate: clocks generated by the CPU core stop function

Memory

- On-chip two-way set associative cache: 16 KB instruction and 16 KB data
- Synchronous DRAM interface with access at 100 MHz
- Memory controller for ROM, synchronous DRAM, and flash memory
- Independent ROM and RAM with 16-/32-bit bus width
- Cache locking for critical code execution

Peripherals

- 32-bit PCI version 2.1 interface operating at 33 MHz
- Fast IR processing in compliance with IrDA specification 1.1
- DMA controller
- Interrupt controller
- General-purpose I/O ports
- Two-channel 16550-compatible serial interface
- Serial interface
- Serial debugging interfaces
- Synchronous three-line serial clock
- Real-time clock

Ordering Information

Part Number	Package
μPD30131F1	224-pin FPGA

Development Systems

RockHopper™ family development systems are available for purchase. Includes two options with or without Baseboard. See the RockHopper family product brief (Document No.: 50398-2) for more details.

Part Number	
DDB-VR4131A	Complete kit with baseboard
CMB-VR4131A	Kit without baseboard

VR4131

64-Bit MIPS® RISC Microprocessor

The information in this document is current as of January 2003. The information is subject to change without notice. For actual design-in, refer to the latest publications of NEC Electronics data sheets or data books, etc., for the most up-to-date specifications of NEC Electronics products. Not all products and/or types are available in every country. Please check with an NEC sales representative for availability and additional information. No part of this document may be copied or reproduced in any form or by any means without prior written consent of NEC Electronics. NEC Electronics assumes no responsibility for any errors that may appear in this document. NEC Electronics does not assume any liability for infringement of patents, copyrights or other intellectual property rights of third parties by or arising from the use of NEC Electronics products listed in this document or any other liability arising from the use of such NEC Electronics products. No license, express, implied or otherwise, is granted under any patents, copyrights or other intellectual property rights of NEC Electronics or others. Descriptions of circuits, software and other related information in this document are provided for illustrative purposes in semiconductor product operation and application examples. The incorporation of these circuits, software and information in the design of customer's equipment shall be done under the full responsibility of customer. NEC Electronics no responsibility for any losses incurred by customers or third parties arising from the use of these circuits, software and information. While NEC Electronics endeavors to enhance the quality, reliability and safety of NEC Electronics products, customers agree and acknowledge that the possibility of defects thereof cannot be eliminated entirely. To minimize risks of damage to property or injury (including death) to persons arising from defects in NEC Electronics products, customers must incorporate sufficient safety measures in their design, such as redundancy, fire-containment and anti-failure features. NEC Electronics products are classified into the following three quality grades: "Standard", "Special" and "Specific". The "Specific" quality grade applies only to NEC Electronics products developed based on a customer-designated "quality assurance program" for a specific application. The recommended applications of NEC Electronics product depend on its quality grade, as indicated below. Customers must check the quality grade of each NEC Electronics product before using it in a particular application. "Standard": Computers, office equipment, communications equipment, test and measurement equipment, audio and visual equipment, home electronic appliances, machine tools, personal electronic equipment and industrial robots. "Special": Transportation equipment (automobiles, trains, ships, etc.), traffic control systems, anti-disaster systems, anti-crime systems, safety equipment and medical equipment (not specifically designed for life support). "Specific": Aircraft, aerospace equipment, submersible repeaters, nuclear reactor control systems, life support systems and medical equipment for life support, etc. The quality grade of NEC Electronics products is "Standard" unless otherwise expressly specified in NEC Electronics data sheets or data books, etc. If customers wish to use NEC Electronics products in applications not intended by NEC Electronics, they must contact NEC Electronics sales representative in advance to determine NEC Electronics's willingness to support a given application.

(Note)

(1) * NEC Electronics" as used in this statement means NEC Electronics Corporation and also includes its majority-owned subsidiaries.

(2) * NEC Electronics products" means any product developed or manufactured by or for NEC Electronics (as defined above).

To find out more about the products and services available from NEC Electronics America, Inc.
call 1-800-366-9782

or visit our web site at www.necelam.com